

# Signal Isolation Card

For Placid Industries KB & KC large series magnetic particle brakes & clutches -

The Signal Isolation Card powers the Placid Industries U-B ultrasonic sensor. The card's 0-10 volt D.C. output signal can control your constant-current D.C. power supply. The card's 0-10v output is scaled by a remote potentiometer, to adjust web tension in an unwind or rewind system.

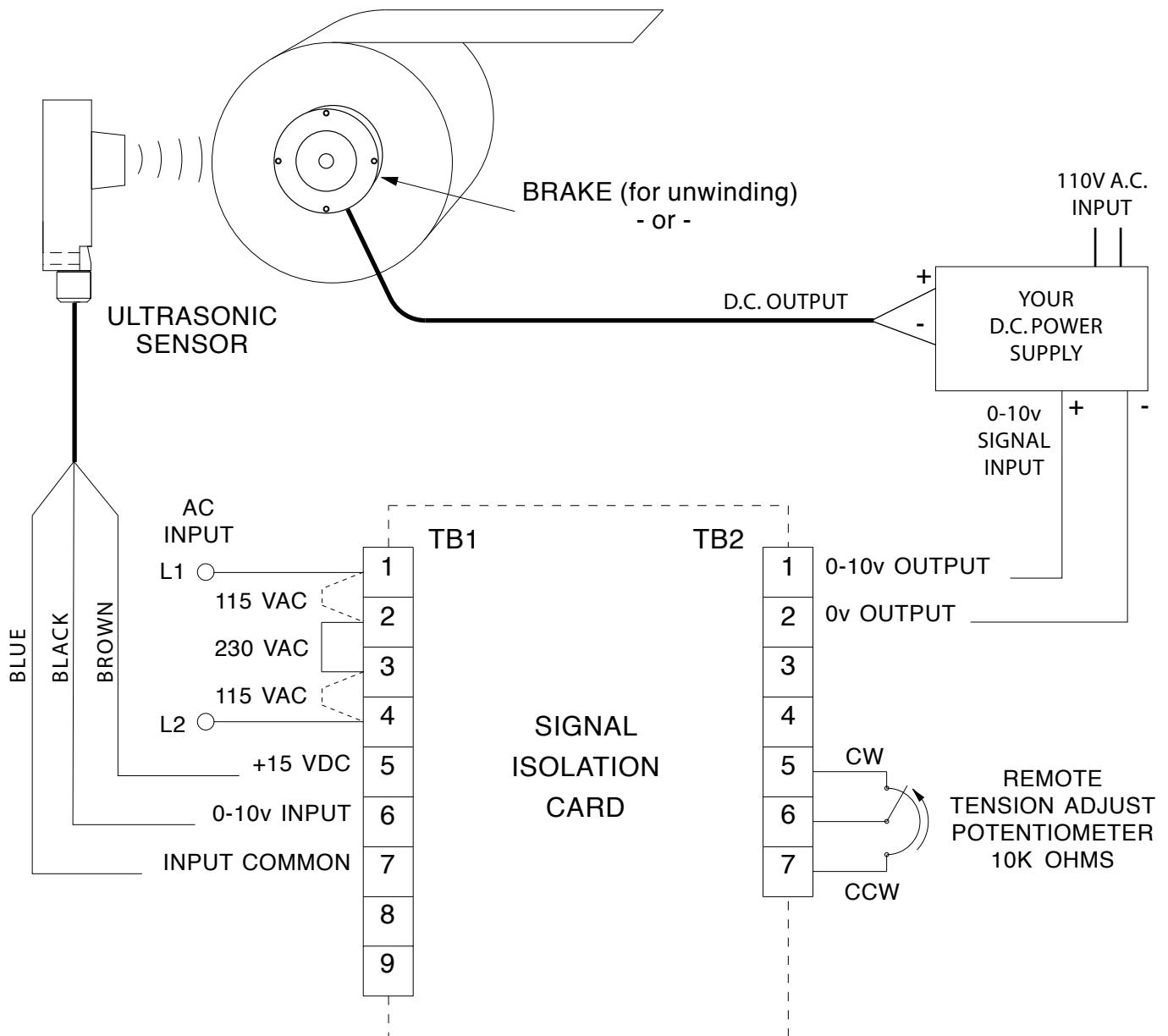

# Signal Isolation Card

## MOUNTING DIMENSIONS

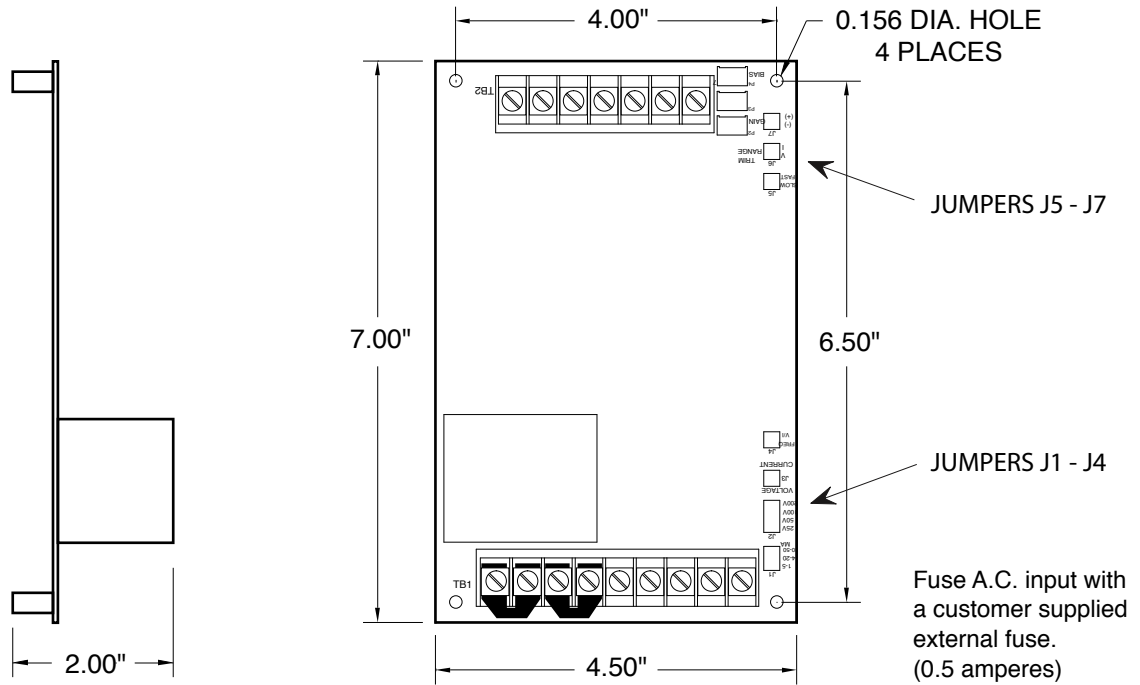

## A.C. INPUT JUMPER CONNECTIONS

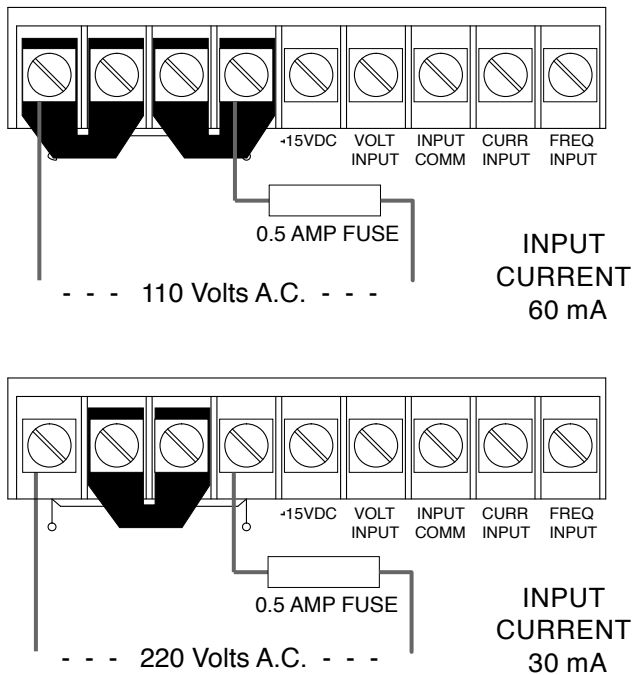

## JUMPERS

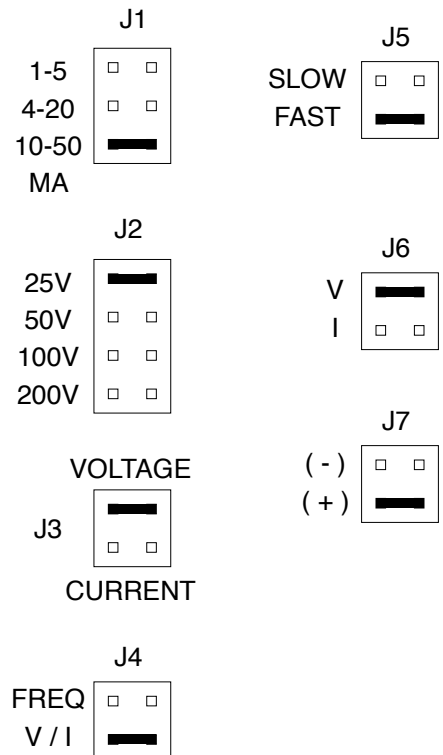

Placid Industries, Inc.

139 Mill Pond Drive, Lake Placid, NY 12946 USA

www.placidindustries.com

Phone 518 523-2422

Fax 518 523-2746

1/05

P2/4

# Signal Isolation Card

## ADJUSTMENTS - Trim Range, Offset & Bias

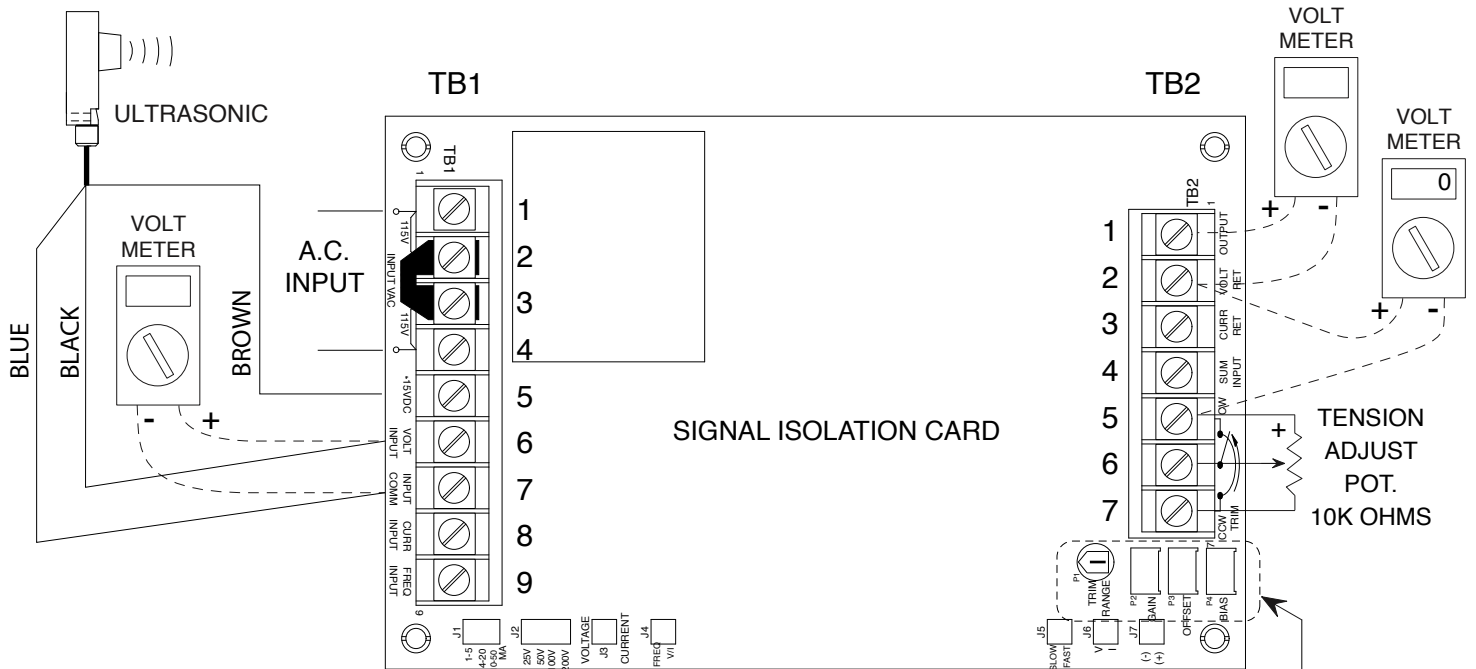

JUMPER FOR 220 VAC SHOWN.

Connect all wires to Signal Isolation Card as shown on page 1 & 2.  
(Connect your power supply later.)  
Set jumpers as shown on page 2.

**The following adjustments are already set at the factory.  
The user can set to initial factory settings by:**

Turn the 'TRIM RANGE' potentiometer fully counter clockwise (1/2 turn pot).

\* AVOID CONTACT WITH ENERGIZED A.C. INPUT TERMINALS.

Apply A.C. power to the Signal Isolation Card (SIC). Verify that the ultrasonic sensor is powered, by listening for a quiet buzzing sound.

Point the ultrasonic sensor away from any target, so it's output is 0 volts. Verify voltage with a portable D.C. voltmeter between terminals TB1-6 and TB1-7.

Turn the remote TENSION ADJUST POT fully clockwise. Turn the GAIN pot. full clockwise (approximate 20 turns until it clicks). Adjust the OFFSET pot. for 0 volts D.C. between TB2-2 and TB2-5.

Turn the GAIN pot. & remote TENSION ADJUST pot. full counter clockwise (approximately 20 turns). Adjust the BIAS pot. for 0 output volts between terminals TB2-1 and TB2-2.

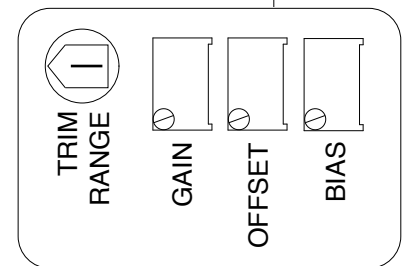

# Signal Isolation Card

---

## ADJUSTMENTS - Gain

For a drawing of the Signal Isolation Card, showing connections & potentiometers, see page 3.

**BRAKE OR CLUTCH SPECIFICATIONS** - Find the 100% rated input current for the Placid Industries brake or clutch from the list below. For Placid Industries KB brakes and KC clutches, coil voltage is 0 - 24 volts D.C.

MODEL (KB or KC)	100% RATED INPUT CURRENT ( amperes )
2.5	1.3
5	1.9
10	2.4
20	2.2
40	3

### SELECT A POWER SUPPLY

Choose a power supply that is a constant current type, with an output voltage range 0-24 volts D.C. (0-30 volts is OK), with an output current rating equal to, or higher than the Placid brake or clutch. Power supply output current should be controllable with a 0-10v signal.

### CALCULATE MAXIMUM 0-10v SIGNAL VOLTAGE

Find the output current for your constant current power supply, when the input 0-10v signal is 10 volts. Calculate the maximum 0-10v signal needed, so your power supply will output the 100% rated input current for the Placid Industries brake or clutch:

$$\text{Max. 0-10v Signal (volts)} = [ \text{Brake 100\% Input Current} ] / [ \text{Max. Power Supply Current} ] \times 10$$

**PROGRAM THE U-B SENSOR** - \* AVOID CONTACT WITH ENERGIZED A.C. INPUT TERMINALS ON THE SIGNAL ISOLATION CARD. Apply A.C. power to the Signal Isolation Card (SIC). Verify that the ultrasonic sensor is powered, by listening for a quiet buzzing sound. Program the U-B ultrasonic sensor, using pages 2, 5 & 6 of the ultrasonic directions.

**GAIN POTENTIOMETER SETTING** - Place a target at the closest distance that the ultrasonic would ever sense (largest roll size) for the following adjustments - - -

Verify ultrasonic sensor output is 10 volts, at terminals TB1-6, TB1-7. Set TENSION ADJUST pot fully clockwise, and then turn GAIN counter clockwise until maximum desired 0-10v signal is reached, as calculated above. The desired maximum 0-10v Signal can be set even lower, if a lower maximum web tension is desired.

**POWER SUPPLY WIRING** - Follow all directions & recommendations of your power supply manufacturer. Connect the SIC's 0-10v output (terminals TB2-1 & TB2-2) to your power supply's 0-10v inputs. Connect the 0-24 volt output of your power supply to the Placid Industries brake or clutch. Connect A.C. power & ground to your power supply. Energize your power supply. Verify maximum input current to brake or clutch is not exceeded. The Signal Isolation Card is now calibrated for operation.

**WEB TENSION ADJUSTMENTS** - Control web tension with the REMOTE TENSION ADJUST potentiometer.

